

Extended Raised Floor Grommet

Part Numbers 10012 and 10013

Installation Guide

Table of Contents

- Preparation and Tools Required for Installation
- Product Components
- Installation Procedures
- Modifications to Product
- General Information
- Warranty



Each carton contains the following items:

- KoldLok Extended Raised Floor Grommets **(10)**
- End Cap Sets—Left and Right Sides **(10)**
- Floor Mounting Kit **(10)**
- Self-Tapping #10 Screws **(50)**
- Product Registration Card **(1)**
- Installation Guide **(1)**

Installation Guide

KoldLok Extended Raised Floor Grommet

Preparation and Tools Required for Installation

Tools Required:

- Bandsaw, table saw, or other appropriate cutting tool
- Hand tools, including bolt cutters, pliers, hammer (or mallet), stake, and metal file

Preparation:

- Remove skirts and tip plates to access the cable cutout.
 - Determine the maximum dimensions of the trimmed cutout. To ensure stability and proper sealing, the KoldLok Extended Raised Floor Grommet should have a minimum surface-to-floor contact of 1 inch (25mm) on three sides of the cutout. Otherwise, the Grommet cannot be used to effectively seal the cutout. Contact Upsite Technologies, Inc. at (888) 982-7800 for customized products and installation services designed to seal larger openings.
 - Determine whether to install Grommets by screwing the product directly to the floor with the self-tapping screws or by using the Floor Mounting Kit.
 - Clean the tile and bottom surface of the KoldLok Extended Raised Floor Grommet using an alcohol wipe or a clean cotton cloth, damp with a solution of at least a 50 percent isopropyl alcohol. Helpful tip: When choosing your cleaning cloth, do not use fabric or paper that will disintegrate or leave particles that could interfere with the adhesive.
 - The KoldLok Extended Raised Floor Grommet can be modified to fit special situations.
-

Product Components (see Figure 1)

1. KoldLok Extended Raised Floor Grommet
2. Right and Left End Caps for protecting and sealing the end of the Grommet
3. Floor Mounting Kit provided as an alternative mounting method if screws cannot be used. The kit includes seven foam strips with 2-sided adhesive backing to adhere the Grommet to the floor, three ESD pads that dissipate static charge by providing a conductive path from the Grommet to the raised floor grounding system, and two strips of double-sided adhesive tape to mount the End Caps to the Grommet.
4. Self-Tapping Screws (5 each) provided as the preferred method of securing the Grommet to the floor tile.

Figure 1

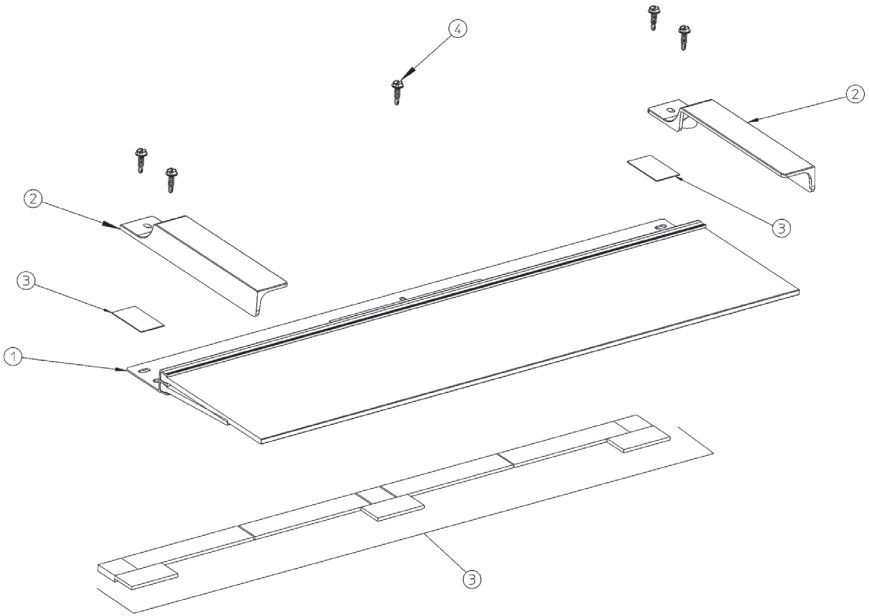

Installation Procedures

Installation Procedure with Self-Tapping Screws:

*IMPORTANT: If the KoldLok Extended Raised Floor Grommets are being installed in an active data center, remove the floor tile and install the Grommet outside of the active data center environment. Following installation, return the floor tile and Grommet to the raised floor.

1. Position the Grommet over the cable cutout, with the flange resting on the floor tile and Grommet filaments covering the cutout.
2. Ensure the flange does not rest on top of any cutout trim. If the Grommet cannot be placed without resting on the cutout trim, install the Grommet with the Floor Mounting Kit. See Installation Procedure with Floor Mounting Kit.
3. Once the Grommet is positioned as desired, drive a self-tapping screw through the center pre-drilled screw hole on the Grommet flange to attach the Grommet to the raised floor.

Installation Guide

KoldLok Extended Raised Floor Grommet

4. Align the screw holes of one End Cap with the screw holes on the end of the Grommet flange. Use self-tapping screws to attach the End Cap and flange to the floor tile. The screw-hole design allows for horizontal and vertical positioning of the End Caps when attaching to the flange. NOTE: With the inside wall of the End Caps mounted against the flange, the installed Grommet can seal an opening the length of a 600mm floor tile. With the End Caps extended away from the flange, the installed Grommet can seal an opening the length of a 24-inch floor tile.
5. Repeat Step 4 with the other End Cap.
6. Attach the Grommet with the remaining screws.
7. Clean any residue that may have been created during installation.

Installation Procedure with the Floor Mounting Kit (see Figure 2):

1. Remove one layer of adhesive backing from the ESD pads and mount on the bottom of the flange at the center and outside corners. The ESD pads should cover the exposed aluminum squares on the bottom of the flange.
*IMPORTANT: To ensure proper electrostatic discharge, ESD pads must adhere to the bottom surface of the flange.
2. Remove one layer of adhesive backing from each of the four 5-inch strips. Mount strips between each ESD pad, along the rear edge of the flange that is furthest away from the brush holders.
3. Remove one layer of adhesive backing from each of the three 2-inch strips. Mount strips above each ESD pad.
4. Remove the second layer of adhesive backing from all seven adhesive strips. Position the Grommet on the floor tile and over the cable cutout.
5. Adhere the unit to the floor. Press down firmly on all portions of the unit to ensure a secure connection to the raised floor surface.
6. Use the two strips of thin double-sided adhesive to adhere the left and right End Caps to the top of the flange.
7. Mount the End Cap to the edge of the flange to ensure that the outside edges of the End Caps are flush with the edges of the floor tile if the cutout spans the full length of the raised-floor tile.

Figure 2 (underside view of the Grommet)

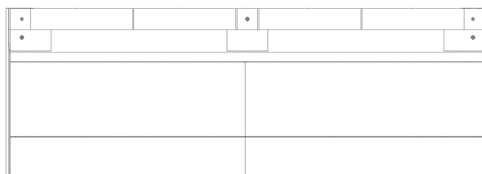

← assembled Floor Mounting Kit

Modification of Extended Raised Floor Grommets

The KoldLok Extended Raised Floor Grommets can be modified to seal large and unique openings. The metal filament channel and Grommet flange may be cut to a desired length. *IMPORTANT: Never cut metal within the raised floor environment.

1. Using a hammer (or mallet) and stake, drive one of the metal filament channels out of the Grommet flange to the desired length.
2. Mark the desired cut line.
3. Use bolt cutters to cut and snap the metal filament channel.
4. Crimp the ends of the metal filament channel with pliers to prevent bristle escape. File any rough or sharp corners and edges.
5. Repeat Steps 1 through 5 above for the other metal filament channel.
6. Mark the empty Grommet flange for cutting. Cut the flange with a saw.
7. File the cut edge of the flange.
8. Use a hammer (or mallet) and stake to reposition the metal filament channel in the Grommet so that the end of the metal filament channel does not protrude from the end of the flange channel.

Step 1



Step 3

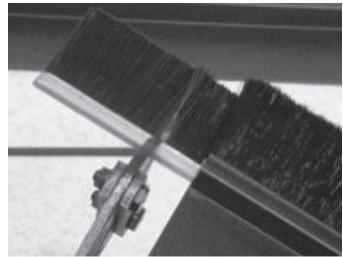

Step 6

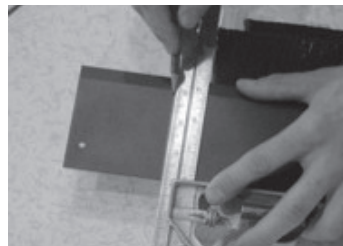

Installation Guide

KoldLok Extended Raised Floor Grommet

General Information

Effective Installation of Cables

In order to minimize any air loss from under the raised floor plenum, make sure to allow for adequate slack in the cables. If the cables are under too much tension, the Grommet filaments may be pulled apart, resulting in a V-shaped gap that will cause an increase in the volume of air escaping from under the raised floor.

Maintaining Proper Cooling of Equipment

Failure to follow computer manufacturer's guidelines for maintaining proper cooling may result in the overheating of equipment. Before sealing cable cutouts, ensure that proper airflow to the intake side of computer equipment or cabinets is feasible through the use of devices such as perforated floor tiles or grates. Achieving proper airflow to the intake side of computer equipment and/or cabinets is the responsibility of the customer.

Cutting Raised Floor Tiles

Each raised floor tile manufacturer provides instructions to properly and safely modify their products. Installers must be familiar with and observe tile manufacturer's recommendations with regard to applicable tools, cutting procedures, the design load capacity of the cut tile, and any additional underfloor support requirements for cut raised floor tiles.

When installing the KoldLok Extended Raised Floor Grommet on a newly cut hole, trim the cutout prior to installation.

Safety Requirements

Installers must be familiar with standard safety and risk management practices when working in raised floor environments and when modifying floor tiles.

Customer Support

If you have any questions, please contact us at: (888) 982-7800, M-F, 9AM-5PM MST or email us at: info@upsitetechologies.com

Upsite Technologies, Inc.
8100 Lang Avenue NE, Suite 301
Albuquerque, NM 87109
Fax (888) 900-1197 | Tel (505) 798-0200
www.upsite.com

Limited Warranty

Upsite Technologies, Inc. (the *Company*) warrants to the original purchaser that products delivered hereunder will be free of defects in materials and workmanship for a period of twelve (12) months from the date of purchase (the "Warranty Period").

The *Company* shall, at its option, within the Warranty Period, either repair or replace free of charge, any product or part thereof found, upon the *Company's* inspection, to be defective in materials and workmanship, and will return the repaired or replaced product to the purchaser at *Company's* expense.

For warranty service and shipping instructions, contact the *Company* at the telephone number shown below. If the product is under warranty and the defect appears to be covered by this Limited Warranty, the *Company* will issue to the purchaser a Notice of Authorization For Warranty Return. Products returned to the *Company* for warranty service must be accompanied by a statement of defect, the Notice of Authorization for Warranty Return provided by the *Company*, and proof of purchase.

This Limited Warranty is conditioned on the following:

1. The *Company* must be notified within 12 months of purchase and have been given the opportunity of inspection by return of any alleged defective product free and clear of all liens and encumbrances to the *Company* or its manufacturer; and
2. The product must not have been abused, misused, or improperly maintained, and/or repaired during such period; and
3. Such defect has not been caused by corrosion or exposure to other than ordinary wear and tear.

The company makes no other express or implied warranty or representation of any kind whatsoever including any warranty of merchantability or fitness for a particular purpose and all such other warranties are hereby included.

The *Company's* maximum liability hereunder is limited to the purchase price of the product. In no event shall the *Company* be liable for any consequential, indirect, incidental, or special damages of any nature arising from the sale or use of the product, whether based in contract, tort, strict liability, or otherwise.

Note: Some jurisdictions do not allow limitations on incidental or consequential damages or how long an implied warranty lasts, so that the above limitations may not fully apply. This warranty gives specific legal rights and you may also have other rights which may vary from jurisdiction to jurisdiction.

For complete warranty and repair information, call (888) 982-7800 or (505) 798-0200.



505.798.0200 upsite.com



800.868.8606
AccessFloorSystems.com