

# KOLDLOK®

## Installation Guide

### KoldLok® 24” Extended Raised Floor Grommet

#### Part Numbers

3” x 24” - 10012

6” x 24” - 10013



## Table of Contents

Preparation Required for Installation	Page 2
Tools and Product Components	Page 2
Installation Procedures	Page 3 & 4
Modifications to Product	Page 5
General Information	Page 6
Warranty	Page 7

### Each carton contains the following items:

- KoldLok Extended Raised Floor Grommets (10)
- End Cap Sets—Left and Right Sides (10)
- Adhesive Mounting Kit (10)
- Self-Tapping #10 Screws (50)
- Installation Guide (1)

## Tools and Preparation Required for Installation

### Tools Required:

- Bandsaw, table saw, or other appropriate cutting tool
- Hand tools, including bolt cutters, pliers, hammer (or mallet), stake, and metal file

Dimensions and Cutting Requirements	Inches (W x D)	Millimeters (W x D)
<b>Item No. 10012 3"x 24" - Overall size</b>	24" x 5.05"	610 x 128mm
Maximum cutout size sealed	24" x 4"	610 x 102mm
Usable cable area	22" x 2.5"	559 x 64mm
Product height above the raised floor	1" w/ mounting kit installed	25mm w/ mounting kit installed
<b>Item No. 10013 6"x 24" - Overall size</b>	24" x 8.08"	610 x 205mm
Maximum cutout size sealed	24" x 7"	610 x 178mm
Usable cable area	22" x 5.5"	559 x 140mm
Product height above the raised floor	1" w/ mounting kit installed	25mm w/ mounting kit installed

### Preparation:

- Remove skirts and tip plates to access the cable cutout.
- Determine the maximum dimensions of the trimmed cutout. To ensure stability and proper sealing, the KoldLok Extended Raised Floor Grommet should have a minimum surface-to-floor contact of 1 inch (25mm) on three sides of the cutout. Otherwise, the Grommet cannot be used to effectively seal the cutout. Contact Upsite Technologies, Inc. at (888) 982-7800 for customized products and installation services designed to seal larger openings.
- Determine whether to install Grommets by screwing the product directly to the floor with the self-tapping screws or by using the Adhesive Mounting Kit.
- Clean the tile and bottom surface of the KoldLok Extended Raised Floor Grommet using an alcohol wipe or a clean cotton cloth, damp with a solution of at least 50 percent isopropyl alcohol. Helpful tip: When choosing your cleaning cloth, do not use fabric or paper that will disintegrate or leave particles that could interfere with the adhesive.
- The KoldLok Extended Raised Floor Grommet can be modified to fit special situations.

## Product Components (see Figure 1)

1. KoldLok Extended Raised Floor Grommet.
2. Right and Left End Caps for protecting and sealing the end of the Grommet.
3. Adhesive Mounting Kit provided as an alternative mounting method if screws cannot be used. The kit includes seven foam strips with 2-sided adhesive backing to adhere the Grommet to the floor and two strips of double-sided adhesive tape to mount the End Caps to the Grommet.
4. Self-Tapping Screws are provided as the preferred method of securing the Grommet to the floor tile.

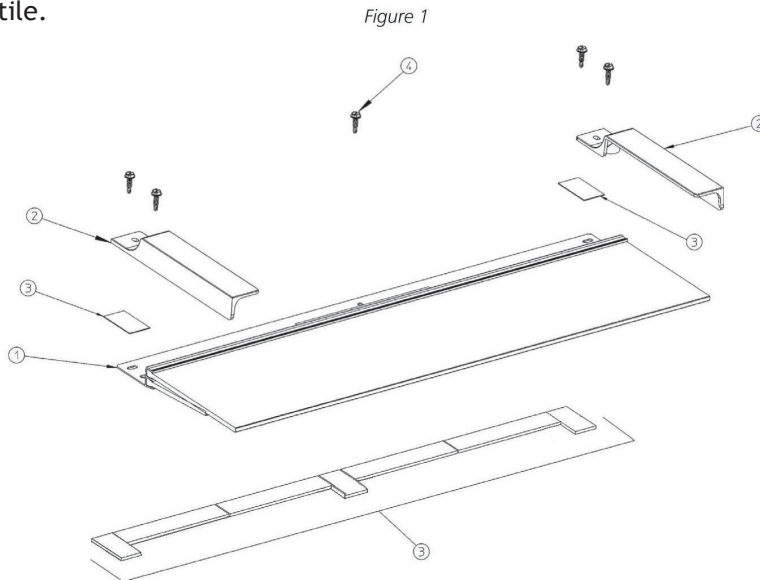

## Installation Procedure with Self-Tapping Screws:

**\*IMPORTANT:** If the KoldLok Extended Raised Floor Grommets are being installed in an active data center, remove the floor tile and install the Grommet outside of the active data center environment. Following installation, return the floor tile and Grommet to the data center.

1. Position the Grommet over the cable cutout, with the flange resting on the floor tile and Grommet filaments covering the cutout.
2. Ensure the flange does not rest on top of any cutout trim. If the Grommet cannot be placed without resting on the cutout trim, install the Grommet with the Adhesive Mounting Kit. See Installation Procedure with Adhesive Mounting Kit on Page 4.
3. Once the Grommet is positioned as desired, drive a self-tapping screw through the center pre-drilled screw hole on the Grommet flange to attach the Grommet to the raised floor.

## Installation Procedure with Self-Tapping Screws Continued:

4. Align the screw holes of one End Cap with the screw holes on the end of the Grommet flange. Use self-tapping screws to attach the End Cap and flange to the floor tile. The screw-hole design allows for horizontal and vertical positioning of the End Caps when attaching to the flange. NOTE: With the inside wall of the End Caps mounted against the flange, the installed Grommet can seal an opening the length of a 600mm floor tile. With the End Caps extended away from the flange, the installed Grommet can seal an opening the length of a 24-inch floor tile.
5. Repeat Step 4 with the other End Cap.
6. Attach the Grommet with the remaining screws.
7. Clean any residue that may have been created during installation.

## Installation Procedure with Adhesive Mounting Kit (see Figure 2):

1. Remove one layer of adhesive backing from each of the three pads and mount on the bottom of the flange at the center and outside corners in a vertical position.
2. Remove one layer of adhesive backing from each of the four 5-inch strips. Mount strips between each vertical pad, along the rear edge of the flange that is furthest away from the brush holders.
3. Remove the second layer of adhesive backing from all seven adhesive strips. Position the Grommet on the floor tile and over the cable cutout.
4. Adhere the unit to the floor. Press down firmly on all portions of the unit to ensure a secure connection to the raised floor surface.
5. Use the two strips of thin double-sided adhesive to adhere the left and right End Caps to the top of the flange.
6. Mount the End Cap

Figure 2: Assembled Adhesive Mounting Kit

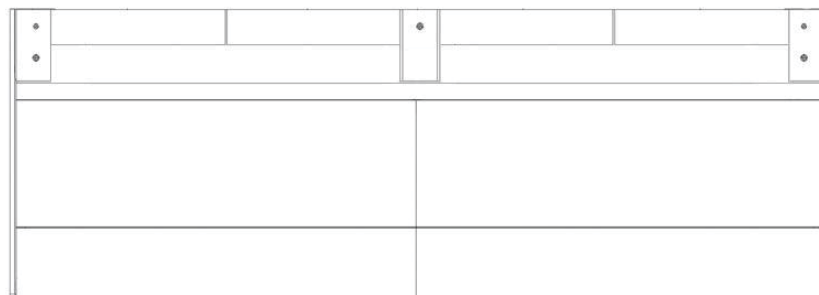

## Modification of Extended Raised Floor Grommets

The KoldLok Extended Raised Floor Grommets can be modified to seal large and unique openings. The metal filament channel and Grommet flange may be cut to a desired length. **\*IMPORTANT:** Never cut metal within the raised floor environment.

1. Using a hammer (or mallet) and stake, drive one of the metal filament channels out of the Grommet flange to the desired length.
2. Mark the desired cut line.
3. Use bolt cutters to cut and snap the metal filament channel.
4. Crimp the ends of the metal filament channel with pliers to prevent bristle escape. File any rough or sharp corners and edges.
5. Repeat Steps 1 through 5 for the other metal filament channel.
6. Mark the empty Grommet flange for cutting. Cut the flange with a saw.
7. File the cut edge of the flange.
8. Use a hammer (or mallet) and stake to reposition the metal filament channel in the Grommet so that the end of the metal filament channel does not protrude from the end of the flange channel.

Step 1



Step 3

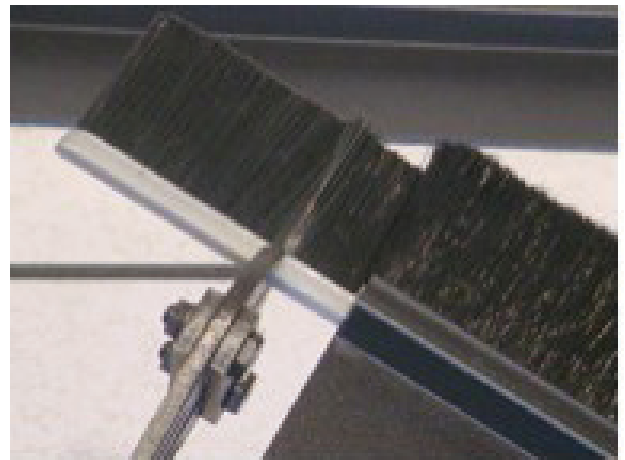

Step 6

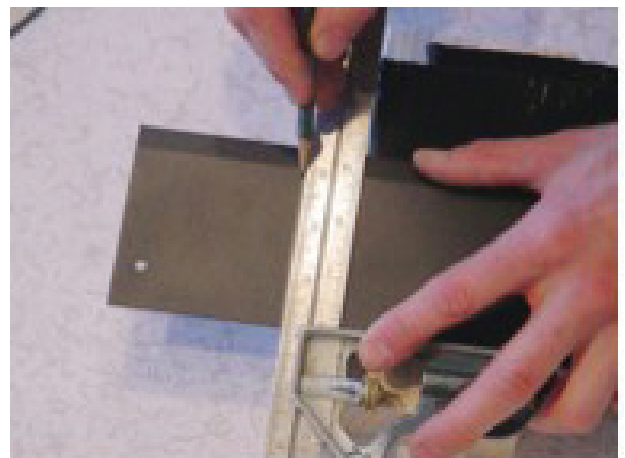

# Installation Guide

## KoldLok® 24” Extended Raised Floor Grommet

### General Information

#### Effective Installation of Cables

In order to minimize any air loss from under the raised-floor plenum, allow for adequate slack in the cables. If the cables are under too much tension, the Grommet filaments may be pulled apart, resulting in a V-shaped gap that will cause an increase in the volume of air escaping from under the raised floor.

#### Cutting Raised Floor Tiles

Each raised floor tile manufacturer provides instructions to properly and safely modify their products. Installers must be familiar with and observe tile manufacturer’s recommendations with regard to applicable tools, cutting procedures, the design load capacity of the cut tile, and any additional underfloor support requirements for cut raised floor tiles.

**When installing the KoldLok Extended Raised Floor Grommet on a newly cut hole, trim the cutout prior to installation.**

#### Maintaining Proper Cooling of Equipment

Failure to follow computer manufacturer’s guidelines for maintaining proper cooling may result in the overheating of equipment. Before sealing gaps between racks, ensure that there is adequate airflow to the intake side of the computer equipment or cabinets through devices such as perforated floor tiles or grates. Achieving proper airflow to the intake side of computer equipment and/or cabinets is the responsibility of the customer.

#### Safety Requirements

Installers must be familiar with standard safety and risk management practices when working on server rack equipment or in data center environments.



P/N 60227 Rev. A © 2012

# Limited Warranty

## KoldLok® 24” Extended Raised Floor Grommet

Upsite Technologies, Inc. (the *Company*) warrants to the original purchaser that products delivered hereunder will be free of defects in materials and workmanship for a period of twelve (12) months from the date of purchase (the “Warranty Period”).

The *Company* shall, at its option, within the Warranty Period, either repair or replace free of charge, any product or part thereof found, upon the *Company*’s inspection, to be defective in materials and workmanship, and will return the repaired or replaced product to the purchaser at *Company*’s expense.

For warranty service and shipping instructions, contact the *Company* at the telephone number shown below. If the product is under warranty and the defect appears to be covered by this Limited Warranty, the *Company* will issue to the purchaser a Notice of Authorization For Warranty Return. Products returned to the *Company* for warranty service must be accompanied by a statement of defect, the Notice of Authorization for Warranty Return provided by the *Company*, and proof of purchase.

This Limited Warranty is conditioned on the following:

1. The *Company* must be notified within 12 months of purchase and have been given the opportunity of inspection by return of any alleged defective product free and clear of all liens and encumbrances to the *Company* or its manufacturer; and
2. The product must not have been abused, misused, or improperly maintained, and/or repaired during such period; and
3. Such defect has not been caused by corrosion or exposure to other than ordinary wear and tear.

**The company makes no other express or implied warranty or representation of any kind whatsoever including any warranty of merchantability or fitness for a particular purpose and all such other warranties are hereby included.**

The *Company*’s maximum liability hereunder is limited to the purchase price of the product. In no event shall the *Company* be liable for any consequential, indirect, incidental, or special damages of any nature arising from the sale or use of the product, whether based in contract, tort, strict liability, or otherwise.

Note: Some jurisdictions do not allow limitations on incidental or consequential damages or how long an implied warranty lasts, so that the above limitations may not fully apply. This warranty gives specific legal rights and you may also have other rights which may vary from jurisdiction to jurisdiction.

**For complete warranty and repair information Call (888) 982-7800 or visit [upsite.com](http://upsite.com)**

**Register your product online at [www.upsite.com/warranty](http://www.upsite.com/warranty) to initiate your warranty.**

U.S. Patent No. 6,632,999 and International Patents Pending