

Magnetic Under Rack Panel

Covers Part Numbers:

- 10226 26" Magnetic Under Rack Panel
- 10227 33.5" Magnetic Under Rack Panel



The 10-pack carton contains:

- (10) AisleLok[®] Magnetic Under Rack Panels
- (1) Installation Guide

! SAFETY REQUIREMENTS

Installers must be familiar with standard safety and risk management practices when working in raised floor environments and when modifying racks and cabinets.

Preparation

AisleLok[®] Magnetic Under Rack Panel

Dimensions and Cutting Requirements	Inches	Millimeters
Part No. 10226 - Overall size (length x height x max depth)	26.0" x 4.75" x .06"	660 mm x 121 mm x 1.5 mm
Maximum Under Rack Sealing Length	24"	610 mm
Part No. 10227 - Overall size (length x height x max depth)	33.5" x 4.75" x .06"	851 mm x 121 mm x 1.5 mm
Maximum Under Rack Sealing Length	31.5"	801 mm

Contact Upsite Technologies, Inc. at (888) 982-7800 for more information on customized products and installation services.

Product Component

AisleLok[®] Magnetic Under Rack Panel (with magnetic strip)

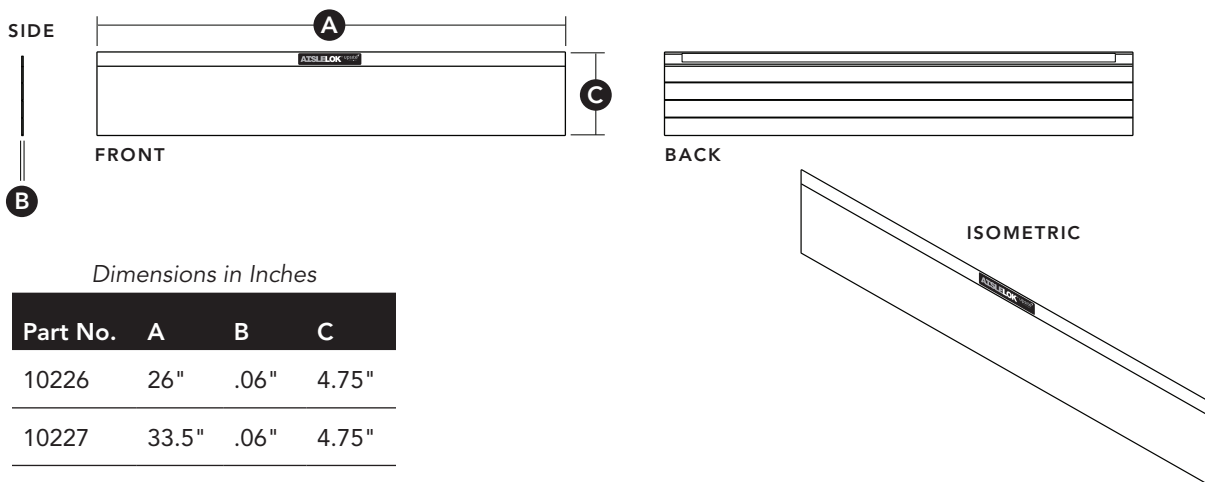

Installation Instructions

AisleLok® Magnetic Under Rack Panel

Installation Procedures

The AisleLok® Magnetic Under Rack Panel fits standard racks, up to 24"W or 31.5"W and is designed to minimize airflow underneath the rack. Before attaching the Magnetic Under Rack Panel, align the Panel with the rack to ensure proper fit location before installation. If required, remove the excess blade material by simply tearing it off by hand in 1" increments.

1. Measure the distance from the bottom of the cabinet to the floor.
2. Determine how long the Under Rack Panel needs to be and remove the excess blade material by tearing each 1" section by hand.
3. Attach the Under Rack Panel to a flat surface on the bottom face of the rack.
4. During installation allow for a 1" overlap between adjacent racks for a better seal.

The Magnetic Under Rack Panel should rest flush on the tile, with no gaps, to minimize airflow underneath the rack. When installed, the Magnetic Under Rack Panel may create an overlap up to 1" on the adjacent racks. The overlap is an intentional design, specifically blocking the bypass airflow between the adjacent server cabinets. The Magnetic Under Rack Panel located at the end of the aisle will need to be trimmed back so the overlap is not protruding.

Installation Note: The Magnetic Under Rack Panels are designed specifically for 24" W or 31.5" W racks. When installed on other rack widths the product label may not be centered with the rack/cabinet door.

Maintaining Proper Cooling of Equipment

Failure to follow computer manufacturer's guidelines for maintaining proper cooling may result in the overheating of equipment. Before minimizing under rack airflow, ensure that proper airflow to the intake side of computer equipment or cabinets is feasible through the use of devices such as perforated floor tiles. Achieving proper airflow to the intake side of computer equipment and/or cabinets is the responsibility of the customer.

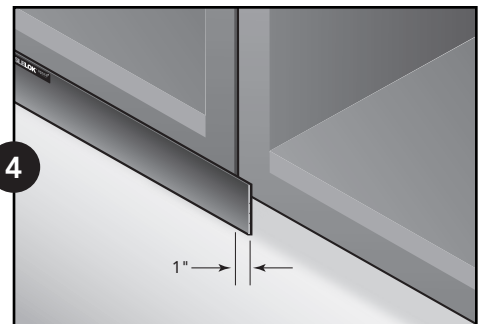
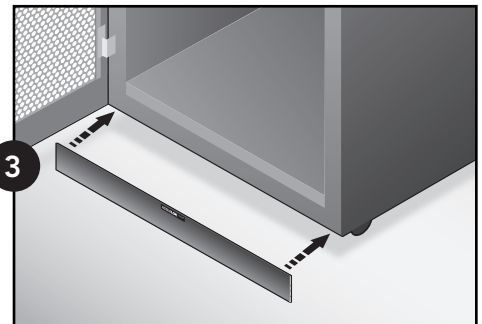
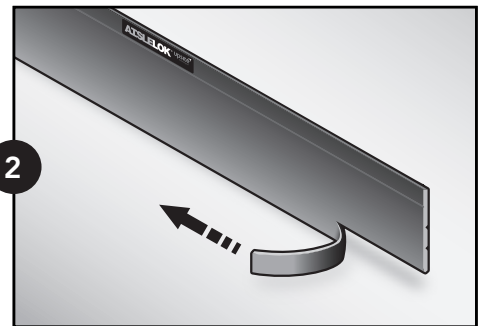
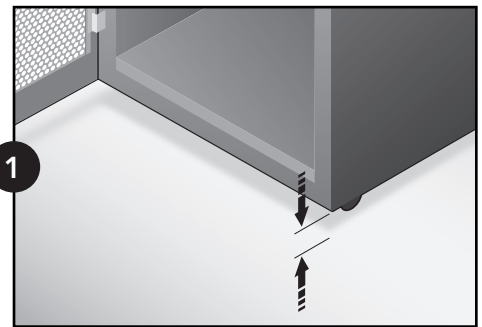

Installation Guide

Limited Warranty

Upsite Technologies, Inc. (the *Company*) warrants to the original purchaser that products delivered hereunder will be free of defects in materials and workmanship for a period of twelve (12) months from the date of purchase (the "Warranty Period").

The *Company* shall, at its option, within the Warranty Period, either repair or replace free of charge, any product or part thereof found, upon the *Company's* inspection, to be defective in materials and workmanship, and will return the repaired or replaced product to the purchaser at *Company's* expense.

For warranty service and shipping instructions, contact the *Company* at the telephone number shown below. If the product is under warranty and the defect appears to be covered by this Limited Warranty, the *Company* will issue to the purchaser a Notice of Authorization For Warranty Return. Products returned to the *Company* for warranty service must be accompanied by a statement of defect, the Notice of Authorization for Warranty Return provided by the *Company*, and proof of purchase.

This Limited Warranty is conditioned on the following:

1. The *Company* must be notified within 12 months of purchase and have been given the opportunity of inspection by return of any alleged defective product free and clear of all liens and encumbrances to the *Company* or its manufacturer; and
2. The product must not have been abused, misused, or improperly maintained, and/or non-Upsite authorized repair performed during such period; and
3. Such defect has not been caused by corrosion or exposure to other than ordinary wear and tear; and
4. The installation and use of the product has been in accordance with the manufacturer's instructions and not been modified or customized to include but not limited to cut, resized, burned, glued, bent, re-shaped, disassembled, attachments added to, improperly installed or used in a manner other than intended.

The company makes no other express or implied warranty or representation of any kind whatsoever including any warranty of merchantability or fitness for a particular purpose and all such other warranties are hereby included.

The *Company's* maximum liability hereunder is limited to the purchase price of the product. In no event shall the *Company* be liable for any consequential, indirect, incidental, or special damages of any nature arising from the sale or use of the product, whether based in contract, tort, strict liability, or otherwise.

Note: Some jurisdictions do not allow limitations on incidental or consequential damages or how long an implied warranty lasts, so that the above limitations may not fully apply. This warranty gives specific legal rights and you may also have other rights which may vary from jurisdiction to jurisdiction.

For complete warranty and repair information Call (888) 982-7800 or visit upsite.com

U.S. and International Patents Pending



AccessFloorSystems.com
PO Box 1148, Abita Springs, LA 70420
985.898.0880, 985.892.8535 fax
www.accessfloorsystems.com